

MODEL: P282TFN

Cast Stainless Steel 2-Piece Full Port Ball Valve



TECHNICAL

ANSI Class 800 (2000 PSI CWP) · NACE MR-01-75 ·
 FNPT Ends Per ANSI B1.20.1 · Fire Safe Design to API 607 (1/4" - 2") ·
 Design & Manufacture Per ASME B16.34 · Inspection & Testing Per API 598 ·
 Temperature Rating for CF8M SS -267°C to 648°C ·
 Temperature Rating for RTFE -195°C to 232°C ·
 Heat Number Tracking/Mill Test Reporting Available

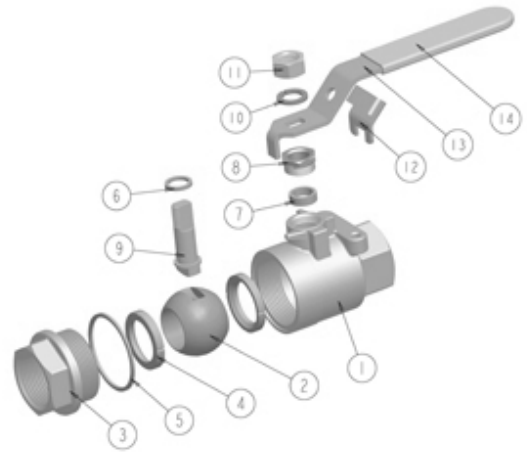
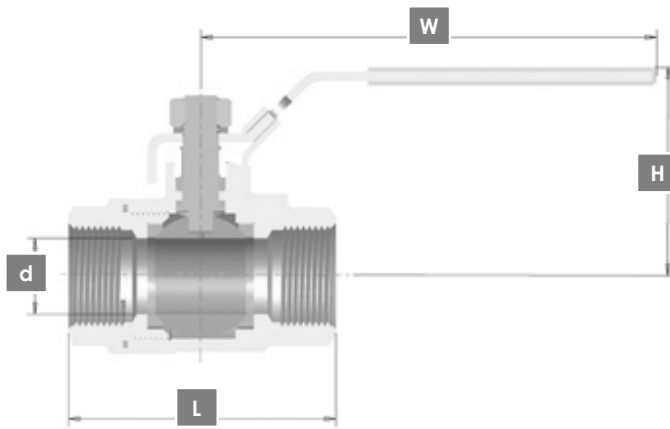

BILL OF MATERIALS

NO.	DESCRIPTION	MATERIAL
1	Body	ASTM A351 CF8M
2	Ball	316 Stainless Steel
3	Cap	ASTM A351 CF8M
4	Seat	PTFE
5	Joint Gasket	PTFE
6	Thrust Washer	PTFE
7	Packing	PTFE
8	Gland	304 Stainless Steel
9	Stem	316 Stainless Steel
10	Spring Washer	304 Stainless Steel
11	Nut	A2-70
12	Lock	201 SS
13	Handle	201 SS
14	Handle Cover	PVC

DIMENSIONAL DATA

SIZE	1/4"	3/8"	1/2"	3/4"	1"	1-1/4"	1-1/2"	2"	3" **
in/mm	8	10	15	20	25	32	40	50	80
d	0.43	0.49	0.59	0.79	0.98	1.26	1.5	1.89	2.97
in/mm	10.8	12.5	15	20	25	32	38	48	75.5
L	2.4	2.4	3	3.1	3.5	4.3	4.7	5.5	7.2
in/mm	60	60	75	80	90	110	120	140	184
H	1.9	1.9	2.3	2.4	3	3.1	3.6	4.1	5.9
in/mm	48	48	58	60	77	79	92	105	151
W	3.9	3.9	4.7	5.5	5.9	6.5	6.5	7.7	12.7
in/mm	100	100	120	140	150	165	165	195	322
WEIGHT	0.66	0.88	0.99	1.4	2.4	4.4	6.6	9.3	21.5
lbs/kgs	0.3	0.4	0.45	0.65	1.1	2	3	4.2	9.75

** P272TFN 3" Valve ANSI Class 400 (1000 PSI CWP) , Seal Weld

Predator Valve makes every effort to ensure the information presented on our literature accurately reflects product specifications. However, as changes occur, there may be short-term differences between actual product specifications and the information shown on our literature. The above technical data is for reference only.

TOUGH
RELIABLE
STRONG

PREDATORVALVE.COM