



**MODEL: CW115FMN**  
 Wafer Double Disk Swing Check Valve



ANSI Class 150

ASME B16.34, NACE MR0175,

Design and manufacture: API 594 and API 6D

Face-to-Face dimensions: API 594

Tests: API 598

Flange Dimensions: NPS 2"-12"- ANSI B16.5

MTR & CRN are available upon request.

**Material Specifications**

No.	Description	Qty	Material
1	Cast Body	1	A216 WCB/A352 LCB
2	Sealing Face Overlay	1	PTFE, 13 Cr and 18Cr-8Ni
3	Disc	2	A216 WCB/ A352 LCB
4	Disc Stem	1	A182 F6
5	Shaft	1	A182 F6
6	Torsion Spring	1	Inconel X750
7	Plugs	4	A216 WCB/A351 CF8M

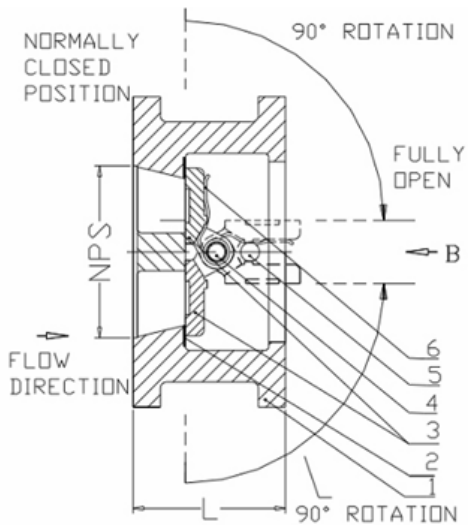

**VIEW B**

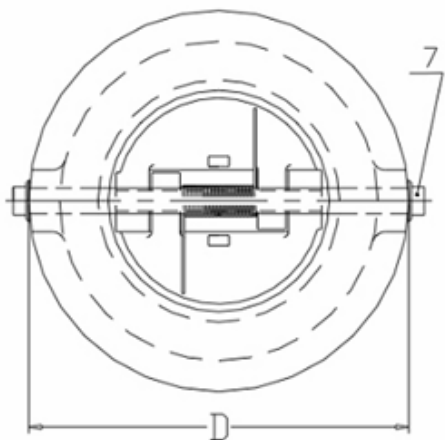

**Dimensions**

NPS	Class 150		
	L, mm	D, mm	Weight kg
2"	60	103	1.2
3"	73	135	3
4"	73	173	7
6"	98	220	15
8"	127	277	23
10"	146	337	30
12"	181	408	37

**STRONG**

**RELIABLE**

**TOUGH**